

INSTRUCTIONS: T1

Date: 12-09-2002

Check: 01



T1 EXTENSIBLE DRIVING BAR

1- INTRODUCTION

2- USE AND MAINTENANCE INSTRUCTIONS

3- ASSEMBLY HANDBOOK

1- INTRODUCTION

The Dynatech extensible driving bars are the perfect complement for every sling maker who use our progressive and instantaneous safety gears system. Compatibility, simplicity and usefulness are the main criterias followed during its design. The result is an important costs saving for our clients.

The only work required is the positioning of the safety gear in the sling. After that, every component supplied by Dynatech will be insatalled in a standard way, without the requirement of any modification, included those caused by the distances between guides because the driving bars are extensibles.

The sling making cost is considerably reduced due to its standard production, reaching the following objectives:

- Decreasing of the number of work hours of the people in charge of the sling making.
- Decreasing of the number of work hours of the people in charge of the product quality control.
- Finantial costs saving (Costs produced by the considerable stocks of the different sling- making elements which would have been needed).
- Delivery time reduction of the product to the client.
- General standardization in all ways: Manufacturing devices, packing, labeling, documentary order, etc....

All these points must be taken in care in order to obtain a good benefit and a great competitiveness for your enterprise.

2- USE AND MAINTENANCE INSTRUCTIONS

All the components are very simple and do not need a special maintenance.

The most important points that must be considered are those:

- 1- The assembly instructions of each driving bar must be respected.
- 2- The screws for the adjustment and fixing of the driving bars to the sling and those for the components of the driving bar have to be tightened with his respective tightening torque in order to guarantee the proper fixing and avoid a wrong driving bar acting.
- 3- The driving bar situation in the sling must be the correct in order to allow the correct safety gear acting as well as avoid the interference of the driving bar with the hollow devices or the guides.
- 4- Knocks and dents must be avoided.

T1 DRIVING BAR ASSEMBLY HANDBOOK

1. Once received, the T1 driving bar should be unpacked and it should be checked that all its components have been received in good conditions (see enclosed components list).
2. **ARMS AND HANDLES ASSEMBLY:** Each arm (2) must be joined to an arm support (1) through a M8x25 SIN 7991 countersinks screws (4). Once together, they must be joined to a handle (5) through two M8 x 16 DIN 933 8.8 (3) screws, making sure that the countersink of the handle is on its inner face, – Fig. 2 –.

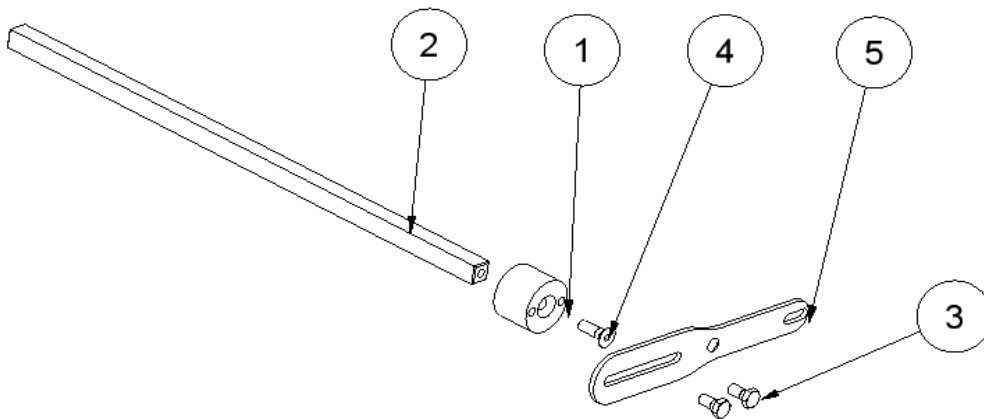

Figure.2

3. **GOVERNOR LINKAGE PLACING:** One of the screwed arms must be fixed to the governor linkage (6), through the M10 x 25 DIN 7991 8.8 screw (7) and the M10 DIN 985 Autoblock nut (8) – Fig. 3 –.

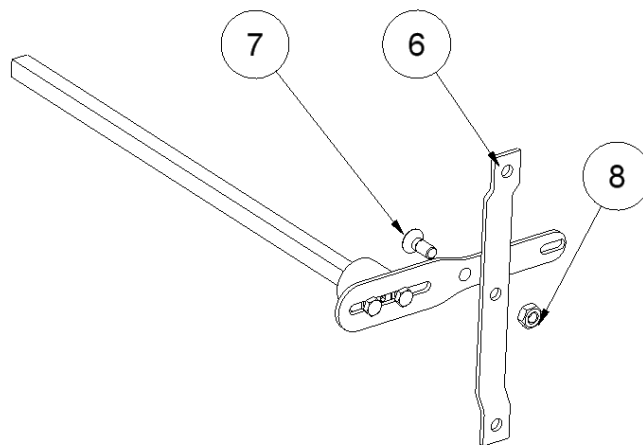

Figure.3

4. MOUNTING PLATES ASSEMBLY:

It must be taken in care during the assembly the fact that the left mounting plate (15) is different than the right one (14). The left support cap (10) is also different than the right one (9). The grooves of the mounting plate will be always at the lower part and its fold will remain parallel to the axle in order to screw together the driving bar and the lift sling (See Fig. 4). The plane face of the support caps must remain parallel to the plate grooves and the thread must always look to the lift sling as it is shown at figure 4. The other components can be used either in one side or in the other side.

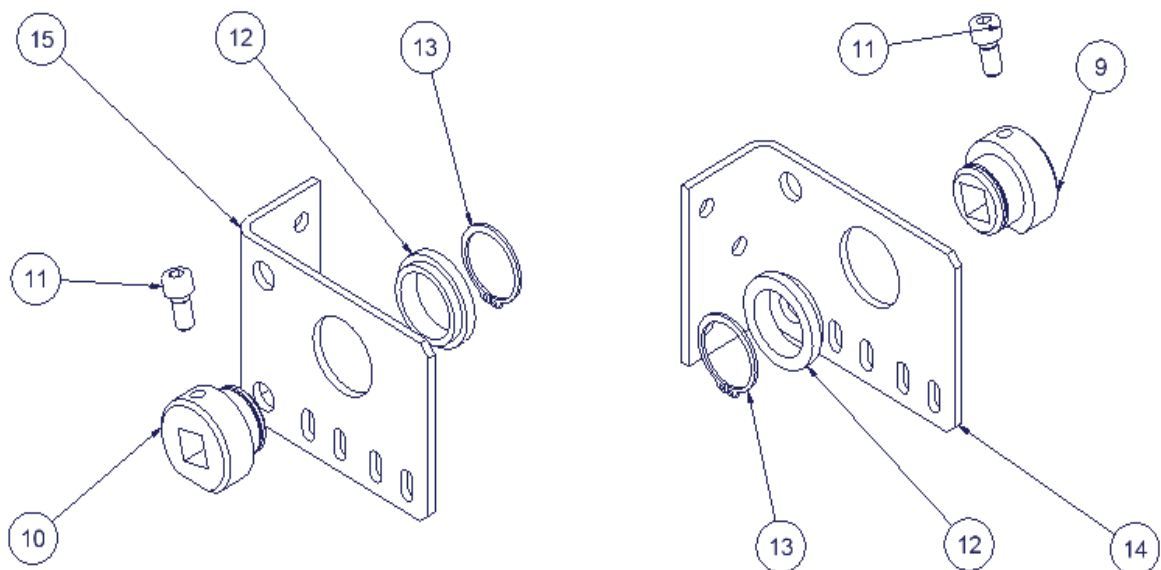

Figure.4

The nylon tips (**12**) must be introduced in each mounting plate in the way shown at Fig.4, later on, the support caps must be inserted from the opposite side, joining them (with the help of stright-end pliers) through a security ring (**13**). Finally, an M8 x 16 DIN 912 8.8 screw (**11**). Must be introduced in each cap. The whole process is shown at figure.4.

- 5. MOUNTING PLATES AND ARMS JOINT:** Before joining the mounting plates and the arms, it should be checked which is the right plate and which is the left one. The arm with the governor linkage (**6**) must be introduced in the plate of the side where the lift speed governor is placed and the arm without the governor linkage will be introduced in the oder plate. The support cap screw (**11**) must be tightened in order to fix together the mounting plates and the arms - Fig. 5

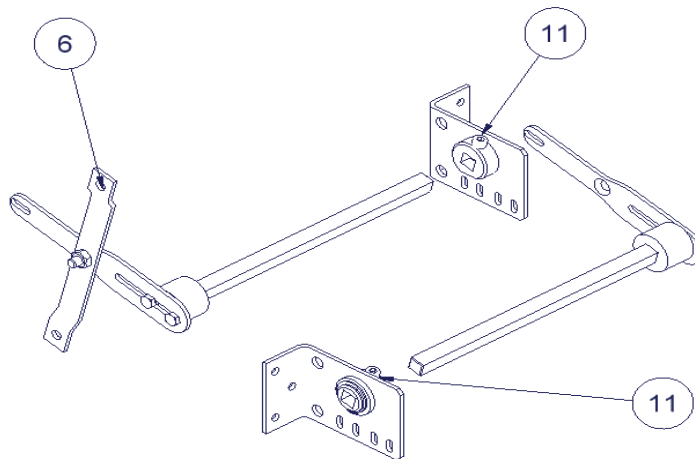

Figure.5

It is recommendable to fix definitively the screw after having placed the driving bar at the sling in order to improve its adjustment.

- 6. TENSOR AND SPRING PLACING:** The tensor (**18**) and the spring (**16**) must be assembled at the left side of the driving bar, and if it is possible it will be assembled at the side of the governor linkage (**6**), First of all the spring and the tensor must be inserted in the arm of that side. The spring is fixed to the tensor through a M6x10 DIN 7991 8.8 (**19**) and the other end of the spring must be fixed to one of the grooves placed on the mounting plate. Finally, the tensor is fixed to the driving bar arm through two M6x8 DIN913-45 H (**17**). The tensor must be prestressed in order to allow the spring to keep the handle in the lower position. – Fig. 6 –.

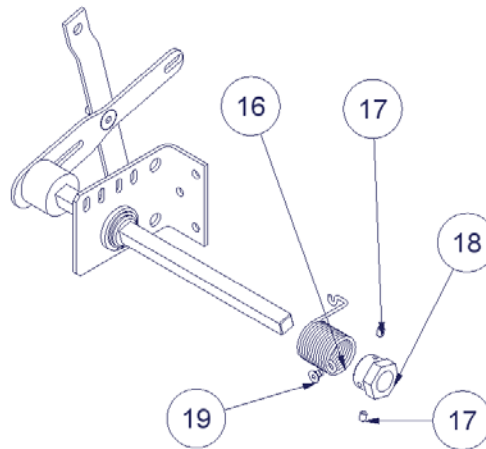

Figure .6

7. DRIVING BAR AXLE PLACING: The endings of the driving bar axle (20) must be screwed together with each arm through M8 x 10 DIN 933 8.8 screws (21) - Fig.7 -.

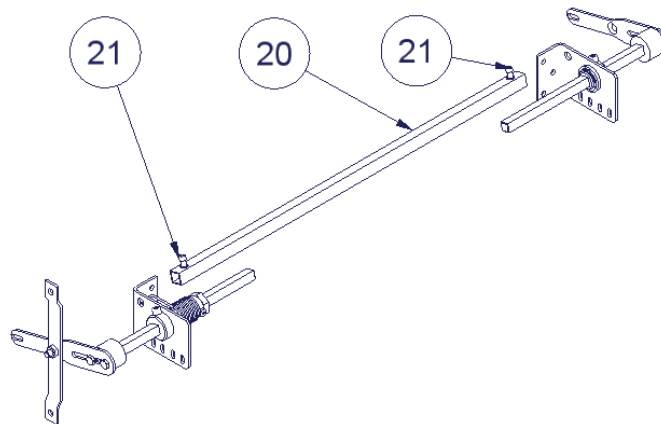
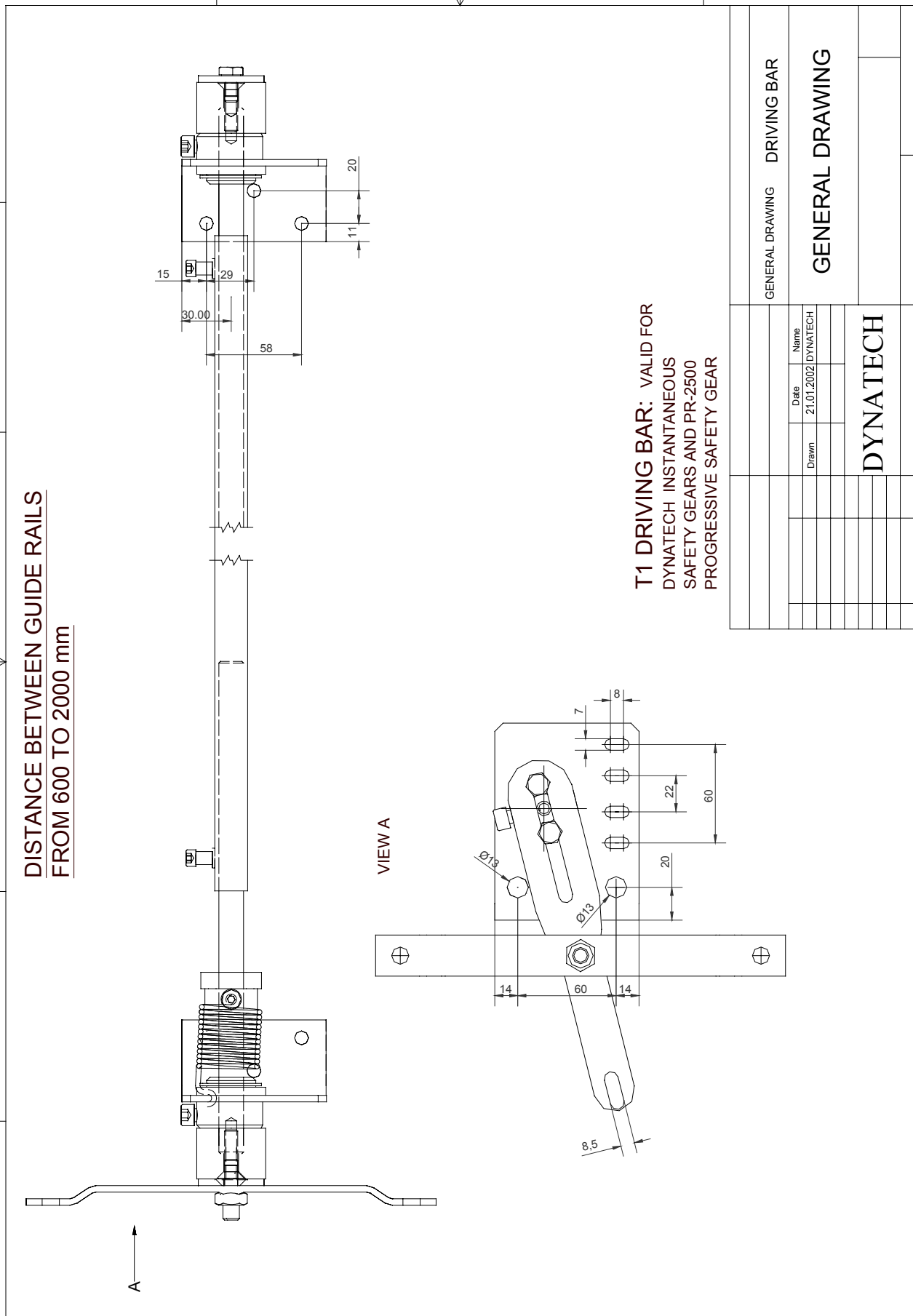
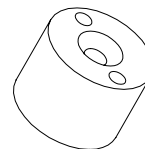
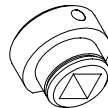
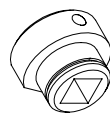
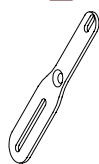
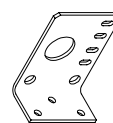
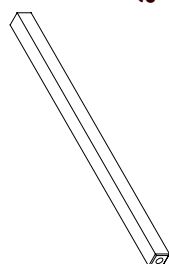
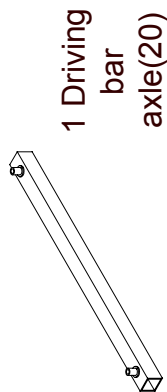

Figure.7

The definitive fixing of the screws should be done after being placed the driving bar at the sling in order to center the axle to the lift sling. For a correct fixing, these screws have only to be screwed 90 degrees once they are in contact with the arms.



DYNATECH DYNAMICS & TECHNOLOGY	T1 DRIVING BAR COMPONENTS IDENTIFICATION	DATE: 21/03/02
		PAGE: 1 DE 1



- | | |
|-------------------------------------|--------------------|
| 4 Screws DIN 933 8.8 M8x16 (3) | 1 Spring (16) |
| 2 Screws DIN 912 8.8 M8x16 (11) | 2 Plastic tips(12) |
| 2 Screws DIN 912 8.8 M6x16 (21) | |
| 1 Screw DIN 7991 10.9 M10x25 (7) | |
| 2 Screws DIN 7991 10.9 M8x25 (4) | |
| 2 Screws DIN 7991 10.9 M6x10 (19) | |
| 1 Nut DIN 985 autoblock M10 (8) | |
| 2 Security rings DIN 471 30x1,5(13) | |
| 2 Screws DIN 913 8.8 M6x8 (17) | |